

Varimixer

FLEXLIFT INOX MINI

EASY HANDLING After mixing, the bowl is lifted directly out of the mixer, driven to the workplace and lifted up to appropriate working height for portioning of the contents.

BOWL HANDLING The Flexlift Inox Mini seizes with two arms around the bowl.

BOWL TURNING The turning unit is used for making sideways rotation of the bowl.

BATTERY POWERED The Flexlift Inox Mini lift will enhance efficiency in your work processes and ensure health and safety.

BOWL SIZES The Flexlift Inox Mini handles bowls from 30 to 60L.

EASY TRANSPORTATION Flexlift Inox Mini handles all lifts of bowls and is easy to drive around in the kitchen.

MAXIMUM LOAD Flexlift Inox Mini moves, lifts and handles loads of up to 50 kg simply and efficiently.

OVERLOAD PROTECTION The lift is equipped with automatic over-load switch.

BOWL FIXATION The two gripping arms are provided with rollers and bent holders. They ensure a good and solid grip on the bowl.

WHEEL BRAKES on both rear wheels

ANTISTATIC WHEELS

WHEN NOT IN USE When Flexlift Inox Mini is not in use, it can be parked under the table.

EASY OPERATION Lifting and lowering is done electrically and is operated from a remote control.

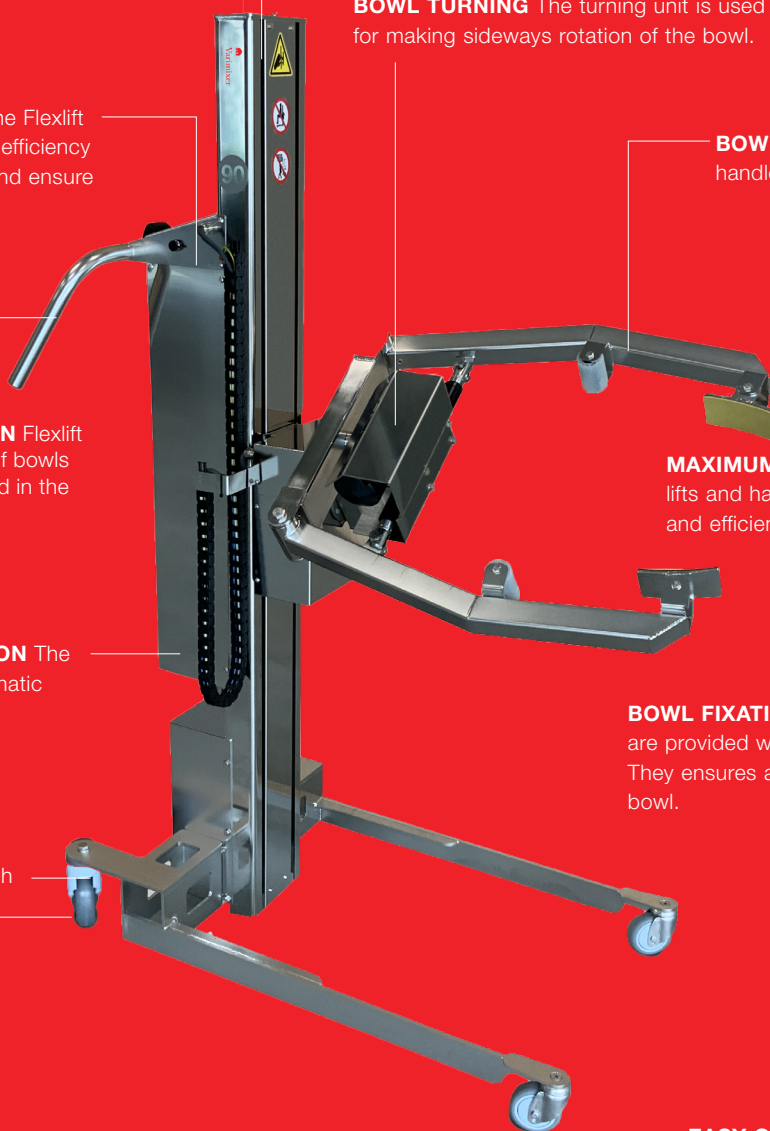

VARIMIXER FLEXLIFT INOX MINI

Mast is made of electro polished stainless steel (1.4301/AISI 304).
Handle is made of electro polished stainless steel (1.4301/AISI 304).
Sledge is made of electro polished stainless steel (1.4301/AISI 304).
Front cover for mast is made of electro polished stainless steel (1.4301/AISI 304).
Remote is made of polyamide 6
Wheel frame is made of electro polished stainless steel (1.4301/AISI 304).
Front wheels are made of polyurethane
Back wheels are made of polyamide and polyurethane
Charger: 230V, 2 Amps

VARIMIXER FLEXLIFT INOX MINI

Bowl size	30 - 60 L
Maximum load	50 kg
Lifting speed (normal speed)	100 - 125 mm/s
Net weight Flexlift Inox M	83 kg
H x W x L Flexlift Inox M	1524 x 553 x 1096 mm
Batteries	24V, 18Ah
Charging time (100%)	8 hrs.
Number of lift per 100% charging	Approx. 50 lifts
Sound pressure level	≤ 70 Db(A)
Vibration strength	≤ 2.5 m/s ²
IP code	IP66

DIMENSIONS FLEXLIFT INOX MINI

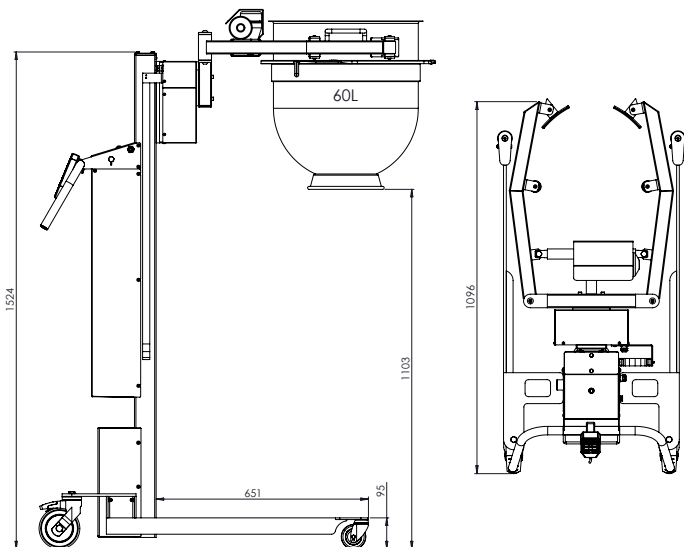

CERTIFICATIONS

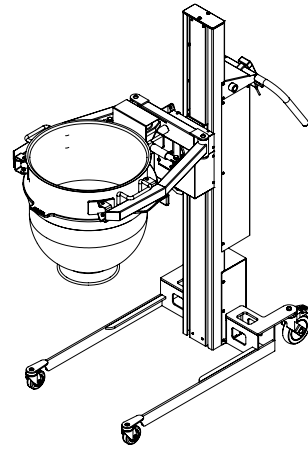

Varimixer

Varimixer A/S
Elementfabrikken 9
DK-2605 Brøndby
P: +45 4344 2288
E: info@varimixer.com
www.varimixer.com